

CHAPTER 1: CRAFT

Origami Boats, Water Bombs + Drinking Cups

Origami is a Japanese word: 'ori' means to fold, & 'kami' means paper. It is the traditional Japanese art of folding paper into interesting shapes. These three basic designs shown here are just the beginning of a whole world of amazing & intricate paper sculptural possibilities.

Make both of these Origami boats, then dip them in wax using the technique on page 8 for some fun in the sun!

Origami Sail Boat

How to make

1 & 2. Take a regular piece of rectangular printer paper and fold it half width ways, then in half again to find the centre.

3 & 4. From the folded edge, fold the top two corners down to the centre line.

5. Then fold the bottom flap upward on each side.

6 & 7. Bring the corners of the base together to create a square shape and fold the flaps under each other to tidy it up.

8. Fold each of these bottom corners up to the top corner on each side. It should look like a triangle. Open up the base of this triangle and squash it into a square shape.

9. Gently pull the side pieces out and unfold it to create a boat shape. Open up the base with your fingers - this will help it to float.

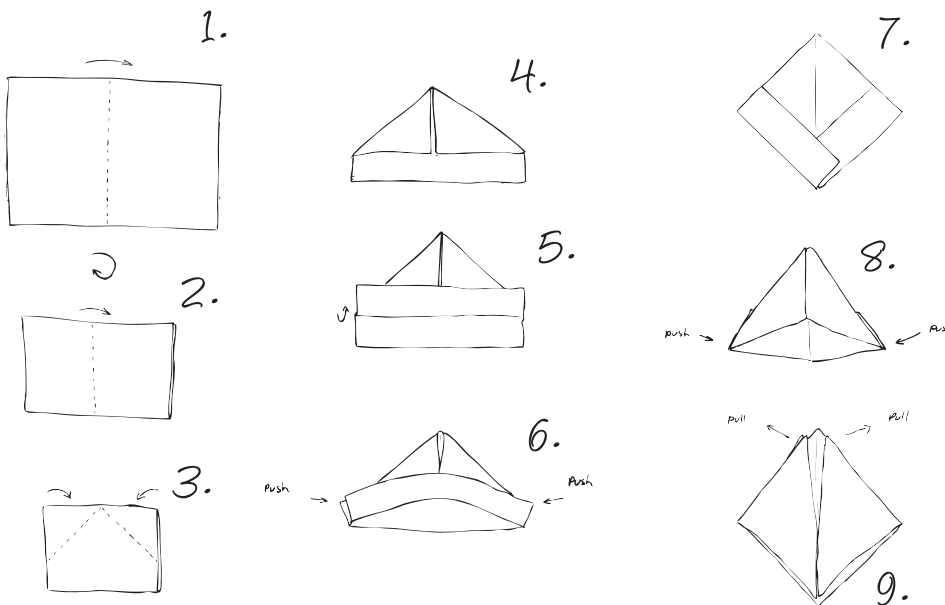
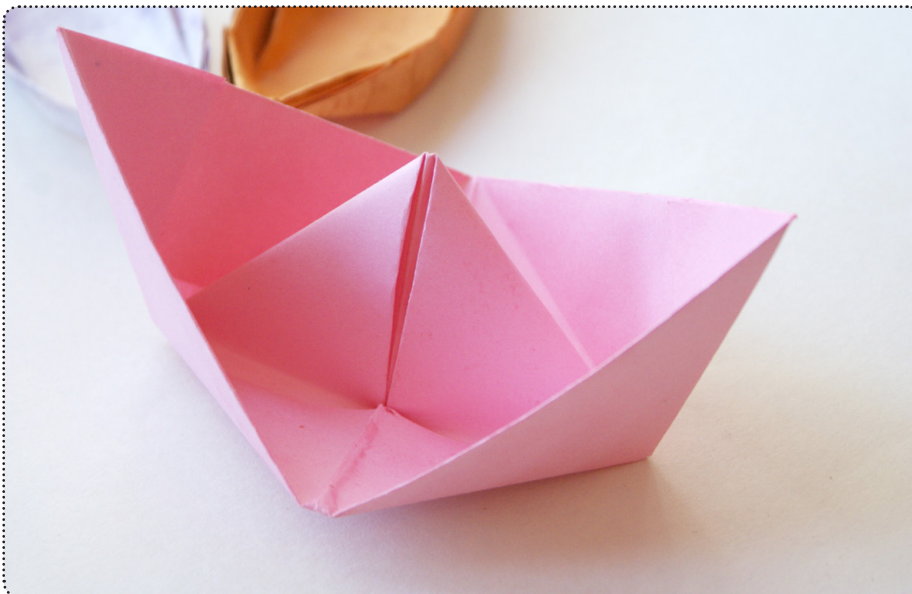

CHAPTER 2: SCIENCE

Beeswax Dipping, Candles + Lotions

You can dip any paper project into beeswax, but it is especially fun with boats, water bombs & cups, as you can wet these & use them over & over again.

Origami Wax Dipping

You will need

- × Your finished origami paper project that you made earlier.
- × Follow the instructions on page 11 for melting your wax.
- × Tongs

How to do it:

1. Take your pot of hot melted beeswax and place it carefully on a heat pad on the table.
2. Hold your origami creations with your tongs and place them carefully into the hot wax. The wax will immediately start to soak into the paper. Use the tongs to carefully rotate the origami piece around so that it soaks up the wax on all sides.
3. After a minute or so use the tongs to remove the origami from the wax and let it drain on a piece of newspaper. It will be cool and dry within a few minutes.

Go and float it in the bath, at the local frog pond, or in your backyard pool.



Warning:

The projects in this chapter involve the use of hot wax. Be very careful when using hot wax as you can easily burn yourself. Make sure an adult has given you permission to do this project & is on standby should you need any help. Be sure to use heat proof gloves & tongs to prevent you from touching the hot wax.



Wax dipping is a great way to make your origami projects last a bit longer.



These boats (and indeed the water bombs too) are ideal to take with you on your adventures.

Go for a walk to your local frog pond, dam or swimming hole. Take these waxed waterproof boats for friendly boat races.

